

HWAWON ELECTRIC INDUSTRIAL CO.,LTD

HW-15CP

Circuit-Breakers for equipment (CBE)

SPECIFICATIONS

Single Pole Thermal Type Breakers

Rating : 3~20A ; 125/250VAC 50VDC

Interrupt Capacity : 1,000A AT 125VAC

Overload Capacity : 6 × RATING

Withstand Voltage : 1,500 VAC/MIN

Approval :  : 3A~15A 125/250VAC

 : 3A~15A 125VAC

 : 3A~16A 250VAC



15CP 15A

EXTERNAL DIMENSIONS

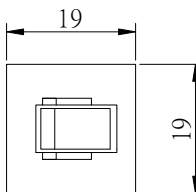
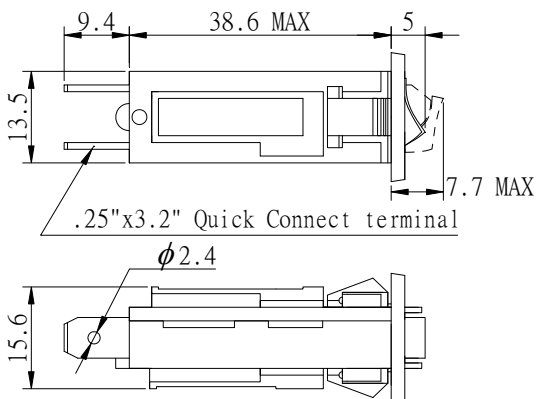

CALIBRATION

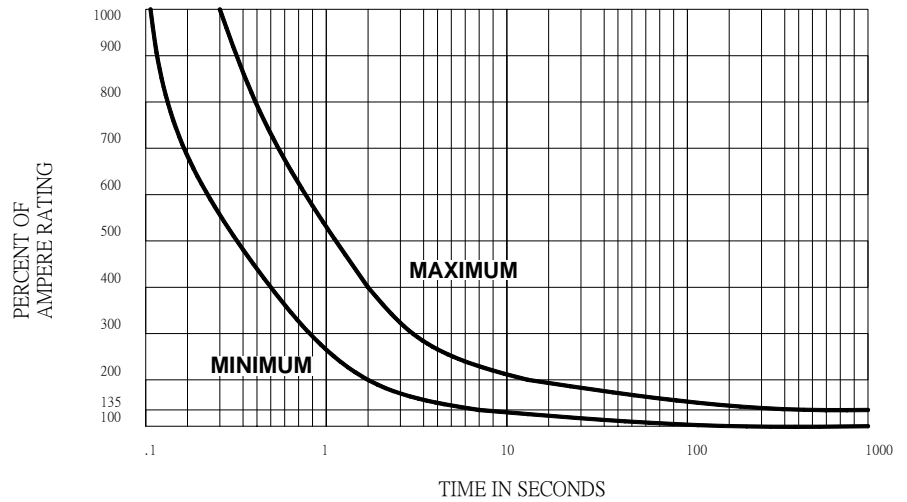

※ 15CP TYPE= 15CP+Rating

MOUNTING DIMENSIONS

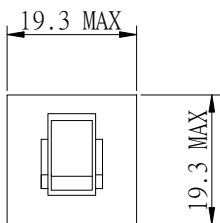

PANEL THICKNESS

A : 1.0 ~ 2.0 mm

B : 2.0 ~ 2.8 mm

RECOMMENDED PANEL CUT OUT

